



Design of Automatic Electricity Inverter

Narendra Nanotkar¹, Shubham Thakre¹, Gaurav Nagoshe¹, Akshay Donode¹, Ashish Thakre²

Final Year Student, Department of Electronics and Communication Engineering, Manoharabhai Patel Institute of Engineering and Technology, Bhandara (RTM Nagpur University) M, India¹

Assistant Professor, Department of Electronics and Communication Engineering, Manoharabhai Patel Institute of Engineering and Technology, Bhandara (RTM Nagpur University) MH, India²

Abstract: The main purpose of this project is to design and verification of a 1000 Watts 220 Volts inverter at a frequency of 50Hz. The inverter is one of the most important and most important components in an independent energy system. It provides power supply when there is cut in government power supply. It plays very important role in areas where there is regular cuts in power supply. It works on the basic principal of charging and discharging of battery. This device is constructed with locally sourced components and materials of regulated standards. The basic principle of operation is a simple conversion of 12V DC into 220V AC from a battery using integrated circuits and semiconductors at a frequency of 50Hz, across the windings of a transformer. Our aim behind this project is to provide an additional power supply at and with the same power output.

Keywords: Integrated Circuits, Pure Sine Wave Inverter, Transformer, Power Supply, Microcontroller.

I. INTRODUCTION

The inverter is one of the most important components in an independent energy system. An inverter converts direct current to alternating current, and also changes the voltage. In other words, we can say that it is a power adapter. It allows a battery-based system to run conventional home appliances like television, fan, computer, etc. through conventional home wiring. We can use direct current directly, but for a modern lifestyle, we need an inverter for the vast majority. It provides power supply when there is cut in government power supply. It plays very important role in areas where there is regular cuts in power supply. It works on the basic principal of charging and discharging of battery. [1] The harmonic content of pure sine wave inverter is very low with good power quality. Such type of inverter are mostly required for sensitive equipment, which cannot withstand fluctuations, in rush current and any other problems caused by high harmonic content. Our aim is to make an economical pure sine wave inverter so that it may be available at affordable price for home users, cottage industries, small-scale business, etc. For this purpose we will analyse the inverters on the basis of switching schemes, on the basis of levels and on the basis of transformer. From that analysis we designed an inverter which is used to run home appliances like fan, light, computer, television. [2]

II. LITERATURE SURVEY

Windy Dankoff, "How to Choose an Inverter for an Independent Energy System", Home Power #82, April-May 2001, PP 74-78 [1], in this document, author gave Brief idea about choosing an inverter. He discuss different parameter like where it is to be used, what type of loads

(appliances) you will be powering, the maximum power the inverter will need to handle, the quality of the power critical, size and weight of inverter, etc. Also he provides inverter selection table that will help to determine what type of inverter is best for design.[1]

J. C. Osuwa and C. F. Peter, "Construction and Implementation of 1 KVA Inverter", in these paper, author gives the brief idea about the production of solid state inverters which provides environmentally friendly alternative for uninterruptible power supply for the working of different gadgets and for sustainable economy. This study is thus anchor on the making of 1 KVA inverter for provision of power using locally sourced 80 Ah 12 volts deep cycle battery, oscillator determined MOSFETs and a transformer along with other electronic components.[2]

In build an inverter for the conversion of DC to AC at a normal frequency of 50 Hz, due consideration is given to the switching speed of the oscillator used to make sure that the MOSFETs in their two channels operate in their saturation and cut off states when appropriately driven by oscillator outputs in a way to complement each other

Olusegun O. Omitola, Segun O. Olatinwo and Taiwo R. Oyedare, "Design and Construction of 1KW (1000VA) Power Inverter", in this paper researcher proposed in the modern society, electricity has great control over the most daily activities for instance in domestic and industrial utilization of electric power for operations. Electricity can be generated from public supply to users in different ways including the use of water, wind or steam energy to drive the turbine as well as more recently the use of gas



Generators, astral energy and nuclear energy are as well source of electricity.[3]

An inverter is an electronic device that converts electrical power from DC form to AC form. It's typical application is to convert battery voltage (stored D.C voltage) keen on normal house A.C voltage to power electronic devices such as TV, fridge etc. when an A.C power from the national grid is not available.

INVERTER TYPES

There are three similar types of inverters depending on their output waveform, these are:

1. Square Wave Inverters
2. Modified Sine Wave Inverters
3. Pure Sine Wave Inverters.

(A) Square Wave Inverters

DC to AC conversion is done using MOSFET switches in the inverter circuit design, which can switch the voltage across the load, giving an output which is an estimate of the regular AC signal. Square wave is the simplest waveform an inverter design can produce and is useful for some applications. For a square wave, the load output is switched from high to low, without an in-between step (i.e. 0V).

In order to send the same amount of power as the sine wave to be approximated, the amplitude of the square wave must be the sine wave's RMS value; this ensures with the purpose of the average power deliver by the two waveforms will be same. Square wave inverters are rarely used in practice, since they have relatively large 3rd and 5th vocal apparatus thus reducing the efficiency of electrical appliances using them. In addition many devices which use timing circuits cannot operate with such rough approximation from square wave inverter output.

(B) Modified Sine Wave Inverter

An upgrade to the square wave inverter is the modified sine wave inverter. Its output is a nonsquare waveform but rough estimate of a sine wave; it is basically a square wave with a pause before the divergence transition, which only needs to cycle through a three-position switch that outputs forward, off, and overturn output at the pre-determined frequency.

Since it is a closer approximation of a true sine wave than is a square wave, most Switched Mode Power Supplies (SMPS) devices such as computers, DVD players can function on quality modified sine wave power. in spite of being much more viable than the square wave, the modified sine wave has some serious drawbacks.

Like the square wave, modified sine wave has fairly huge quantity of power loss (low efficiency) due to significant harmonic frequencies, and devices that relay on the input

power waveform for clock timer will all the time not work properly.

Also devices similar to AC motors directly operated on modified sine wave power can release extra heat, or can have different speed-torque characteristic and produce more audible noise than when running on sinusoidal power.

(C) Pure Sine Wave Inverter

The best power source for most applications is a pure 50 Hz sine wave, identical to the 220Vrms source available on the India national grid. Most appliances are designed to work best with pure sine wave power as it has less harmonic frequencies and much more improved efficiency than the previous ones.

Pure sine wave inverter circuits are extra complex and thus difficult to design and implement thus making them more expensive than the square wave and modified sine wave inverters. Most commercially available inverters are not perfect sine wave but less0 choppy output than the square wave but most manufactures often indicate that they are pure sine wave inverters. There are a lot of advantages of true sine wave over other wave forms deliver by other inverters:

- A) AC powered equipment is designed to operate with true sine wave. Many loads will perform better when connected to the pure sine wave Inverter.
- B) Motor loads start easier
- C) Reduced stress on surge protection circuitry within the equipment means potentially longer equipment life.

Many advantages of true sine wave are also suitable to the lack of the sharp-rising edges of waveforms prevalent in either modified sine wave or square wave inverters. Some of these advantages are:

- (1) Reduced interference in audio or electronic equipment, especially those that use less complex internal power supplies
- (2) Significantly reduced in-rush current into capacitive loads and compact stress on the output strategy of the inverter, potentially lengthening equipment life ii. Motor loads generally operate cooler and quieter without the extra harmonic distortion generated by a modified sine wave.

Hence the use of additional electric power source such as electric power generators and most newly the use of semiconductor power devices such since the Bipolar Transistor, Thyristors and particularly MOSFET to generate electric power in conjunction with a DC battery in few kilowatts.

An Inverter offers a better additional power supply to Generators as well as UPS in view of its long duration, cost effectiveness and maintainability.

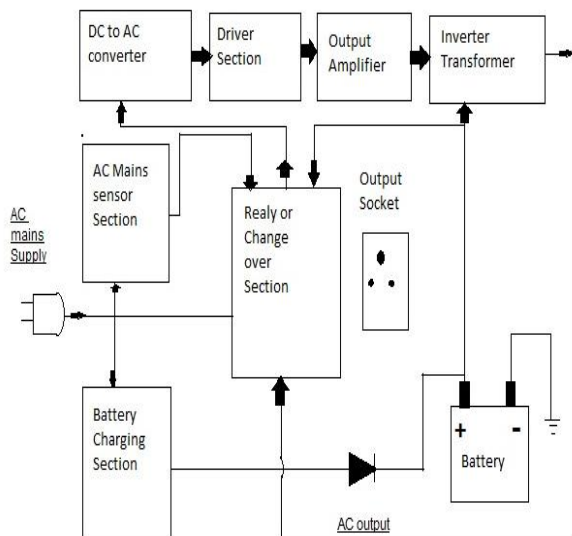

Fig 1: Block diagram of inverter

- Inverter”, IEEE International Power and Energy Conference, 2006, pp. 437-440.
- [7] Jirri Lettl, Jan Bauer, Libor Linhart, “contrast of Different Filter Types for Grid Connected Inverter”, improvement in Electro magnetics Research Symposium (PIERS), 2011, pp, 1426-1429
- [8] Adel S. Sedra, Kenneth C. Smith, “Microelectronic Circuits”, 2004

III. RESULT AND CONCLUSION

The construction of pure sine wave inverter 1000Watts (1KVA), 220Volts inverter at a 50Hz frequency was a regular process from meeting of materials to testing of components. It is observe that the efficiency of this project depends on the power mark of the battery connected to the input and on the whole power of the load connected to its output terminals. Thus, the inverter could deliver constant power for a calculated number of hours.

ACKNOWLEDGEMENT

We would similar to to be grateful to **Prof. I.P. Nikose**, HOD of Electronics and Communication Engineering, MIET, Bhandara, **Prof. Mohammad Naseer** and **Prof. Ashish Thakre**, faculty of Electronics and Communication Engineering, MIET, Bhandara for their guidance, encouragement, valuable comments and suggestions for enhancement the quality of work.

REFERENCES

- [1] Krismadinata Chaniago, J. Selvaraj, N. A. Rahim, “performance of Single-Phase Grid Connected Inverter Using TMS320F2812,” 3rd IEEE Conference on Industrial Electronics and Application, 2008, pp. 1498-1502.
- [2] J. C. Osuwa and C. F. Peter, “Construction and Implementation of 1 KVA Inverter”.
- [3] Olusegun O. Omitola, Segun O. Olatinwo and Taiwo R. Oyedare, “Design and Construction of 1KW (1000VA) Power Inverter”.
- [4] Rafid Haider, Rajin Alam, Nafisa Binte Yousuf, Khosru M. Salim, “plan and Construction of Single Phase Pure Sine Wave Inverter for Photovoltaic function,” International seminar on Informatics, Electronics & Vision (ICIEV), 2012.
- [5] Ahmed Sony Kamal Chowdhury, M. Shamir Shehab, M. Abdul Awal, M. Abdur Razzak, “Design and achievement of a Highly capable Pure Sine-Wave Inverter for Photovoltaic purpose,” International Conference on Informatics, Electronics & Vision (ICIEV), 2013, pp. 1-6.
- [6] B. Ismail, S.Taib MIEEEE, A. R Mohd Saad, M. Isa, C. M. Hadzer, “evolution of a simply Phase SPWM Microcontroller-Based